

(No Model.)

2 Sheets—Sheet 1.

R. T. WINGO. FRICTION CLUTCH.

No. 526,171.

Patented Sept. 18, 1894.

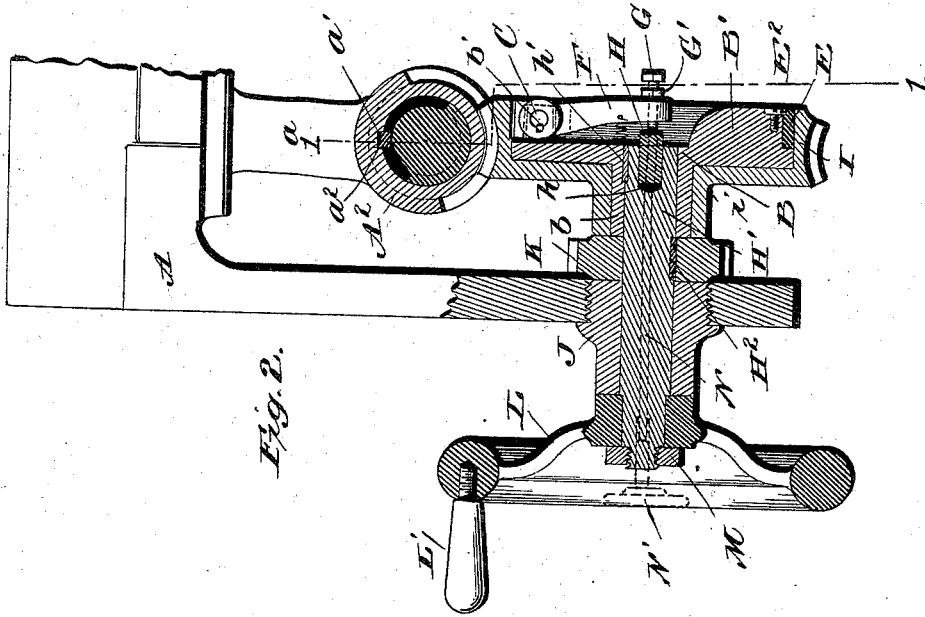

Fig. 2.

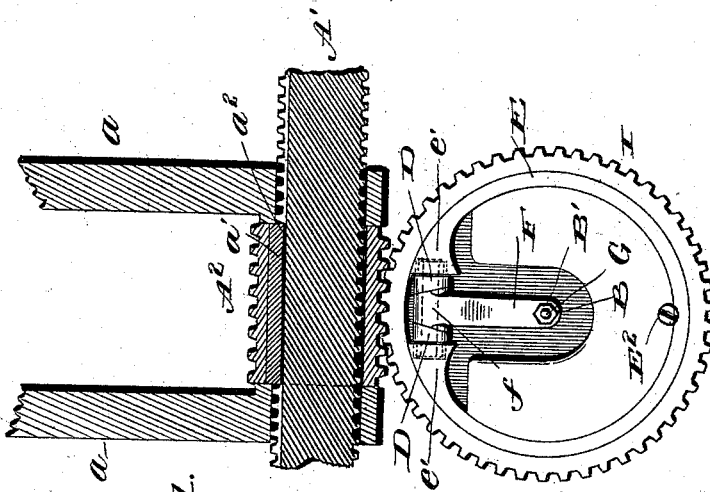

Fig. 1.

Witnesses:
L. C. Mills
E. A. Bond

Inventor:
Richd T. Wingo,
 by *E. B. Stocking*
Attorney

(No Model.)

2 Sheets—Sheet 2.

R. T. WINGO.
FRICTION CLUTCH.

No. 526,171.

Patented Sept. 18, 1894.

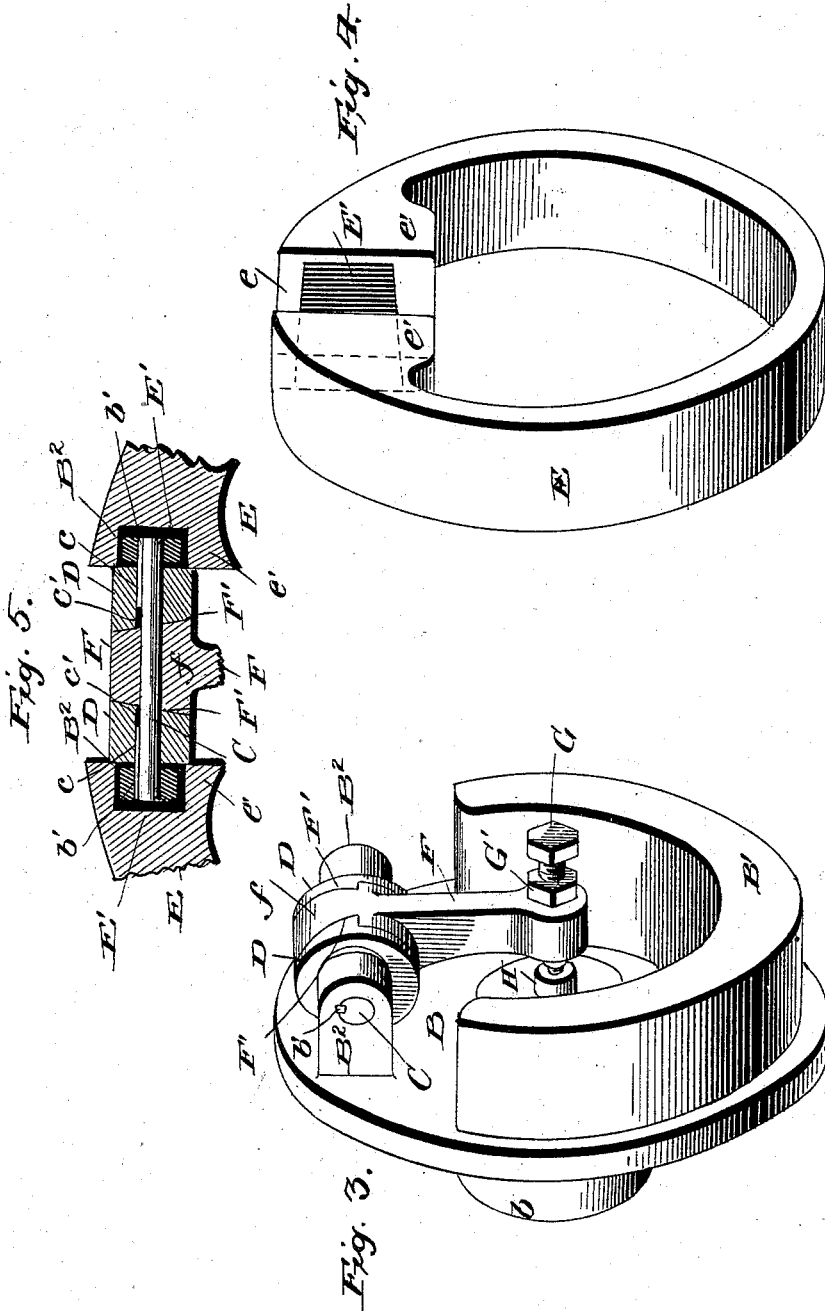

Witnesses
L. C. Mills
E. A. Bond

Inventor
Rich'd T. Wingo.
by *E. B. Stocking*
Attorney

UNITED STATES PATENT OFFICE.

RICHARD T. WINGO, OF MULHAUSEN, GERMANY.

FRICION-CLUTCH.

SPECIFICATION forming part of Letters Patent No. 526,171, dated September 18, 1894.

Application filed April 7, 1894. Serial No. 506,724. (No model.) Patented in France October 6, 1893, No. 233,269, and in Switzerland October 7, 1893, No. 7,472.

To all whom it may concern:

Be it known that I, RICHARD T. WINGO, a citizen of the United States, residing at Mulhausen, Alsace, Germany, have invented certain new and useful Improvements in Friction-Clutches, (for which Letters Patent have been granted to the firm of Ateliers de Constructions Mécaniques, ci-devant Ducommun, in France, No. 233,269, dated October 6, 1893, and in Switzerland, No. 7,472, dated October 7, 1893,) of which the following is a specification, reference being had therein to the accompanying drawings.

This invention relates to certain new and useful improvements in friction clutches of that class in which is employed an expansible ring and means for expanding the same to cause the same to bind against another part to apply the clutch, and has for its object among others to provide a simple clutch of this character of few parts, those readily assembled, efficient and reliable in operation, and durable. It comprises a body portion for carrying the ring and having mounted thereon a shaft or pin on which are mounted for sliding movement cams between which is mounted to turn a double-faced cam carried by a lever. The ring is mounted upon this body portion and has recesses to receive the ears in which the said shaft or pin is mounted. Means are provided for actuating this lever to operate the cam and means are also provided for regulating the throw of the lever and for taking up wear.

Other objects and advantages of the invention will hereinafter appear and the novel features thereof will be specifically defined by the appended claims.

The invention is clearly illustrated in the accompanying drawings, which, with the letters of reference marked thereon, form a part of this specification, and in which—

Figure 1 is a view partly in vertical section and partly in end elevation, the section being taken on the line 1—1 of Fig. 2. Fig. 2 is a substantially central vertical section with portions broken away. Fig. 3 is a perspective view of the body portion. Fig. 4 is a like view of the ring detached. Fig. 5 is a sectional detail showing the ring in place.

Like letters of reference indicate like parts throughout the several views.

Referring now to the details of the drawings by letter, A designates a suitable frame-work, and A' is the lead screw or shaft of a lathe, and on this screw or shaft is placed a worm A² held between suitable supports *a*. In this worm is fitted a spline-key *a'* that slides in a spline *a*² in the screw or shaft as shown in Fig. 2, so that the worm must turn with the screw or shaft. This worm is mounted to mesh with a worm-wheel so that motion is imparted to the other mechanism soon to be described when the friction is engaged.

B is the body portion of my clutch device. It is formed with a hub *b* and with the flange B' extending concentric with its periphery for one half of its circumference, more or less, as seen best in Fig. 3, and with the ears or lugs B² in which is held the pin or shaft C, which is keyed thereto by suitable keys *b'* as seen in Figs. 2, 3 and 5 and on this shaft or pin are arranged the two cams D the adjacent faces of which are oppositely disposed as seen best in Fig. 5, the said cams being mounted to slide endwise of the pin or shaft but held from turning thereon by means of the keys *c* which engage in splines *c'* therein as seen best in Fig. 5, or the spline-keys may be an extension or continuation of the keys *b'* as seen in Fig. 5.

E is the expansion ring. It is slit or split as seen at *e* and its ends are enlarged as shown at *e'* and these enlargements are provided with recesses E' to receive the ears or lugs B² on the body portion as shown best in Fig. 5. This ring is fitted on the body portion and around the flange B' thereof as seen best in Fig. 1, with the ears or lugs B² in the recesses of the ends and the cams D between the ends of the ring as shown in Figs. 1 and 5. The ring is held against displacement by means of a screw E² screwed into the flange of the body portion as seen in Fig. 2 with its head seated in a recess in the said flange and against a shoulder in the ring as seen in Figs. 1 and 2.

F is a lever having at one end the hub *f* which is loosely sleeved upon the pin or shaft C between the two cams D, and the opposite

faces of this hub are inclined in opposite directions as seen best in Fig. 5 to form cams F'. In the other end of this lever is mounted an adjustable screw G which is provided with a set nut G'. The end of this screw bears against a steel point or bearing H which is fitted in a bore or recess h in the end of the shaft H' as seen best in Fig. 2. This shaft passes through the hub of the body portion to which it is splined by a key and spline as seen at h' in Fig. 2. The hub of this body portion is surrounded by the hub i of the worm wheel I which is mounted to mesh with the worm A² as seen in Figs. 1 and 2. This worm wheel is chambered to receive the body portion and its ring as seen in Figs. 1 and 2.

J is a nut screwed into an opening in the frame A and through which nut the shaft H' passes. Between this nut and the ends of the hubs of the worm wheel and body portion is a pinion K which is spline-keyed to the shaft H' by a suitable key H² as seen in Fig. 2 and adapted to mesh with a rack or gear. (Not shown.) Outside this nut J is sleeved upon the shaft a hand wheel L having a handle L' by which it may be turned, and held against displacement by a nut M on the screw threaded end of the shaft as shown in Fig. 2.

N is a rod passed through the shaft H' with its inner end adapted to bear against the end of the steel point H (or, it may be directly against the lever) as shown in Fig. 2 and its outer end provided with a hand wheel or other equivalent device N' by which it may be forced inward or moved out to move out the said steel point or lever.

With the parts constructed and arranged substantially as above set forth the operation is as follows: The worm wheel and the parts carried thereby are revolving continuously. When the lever F is forced outward, as by the rod N, the double cam faces on the hub thereof acting against the cams D spread the ends of the ring and cause the same to engage frictionally with the inner face of the chamber of the worm wheel. As the lever returns to its normal position the resiliency of the ring (which may be aided by a spring) returns it to its normal position, drawing the ends together, the double-faced cam of course

being retracted so as to allow the cams D to slide on their pin toward each other.

Modifications in detail may be resorted to without departing from the spirit of the invention or sacrificing any of its advantages. 55

What I claim as new is—

1. The combination with the body portion having ears, of a pin held in said ears, cams mounted to slide upon said pin, a split spring ring having recesses to receive said ears, and a lever having a hub mounted to turn upon said pin and provided with oppositely-arranged cam faces, substantially as specified. 60

2. The combination with the body portion having ears and a pin held in said ears, of cams mounted to slide upon said pin, a split spring ring having recesses to receive said ears, a lever having a hub mounted to turn on said pin and provided with opposite cam faces acting between and in conjunction with the cams on the pin, and means for actuating the lever to turn said hub, substantially as specified. 65

3. The combination with the body portion having ears and a pin mounted therein, of cams mounted to slide on said pin, a split spring ring having recesses to receive said ears, a lever having a hub provided with oppositely-arranged cam faces and mounted to turn upon said pin, and means for actuating the lever and for varying its throw, substantially as specified. 75

4. The combination with the body portion with flange and ears, a pin held in said ears, and cams mounted to slide upon said pin, of a split spring ring, a lever having a double-faced hub mounted to turn on the pin, a shaft with a steel pin mounted to move therein, a screw mounted in the end of the lever to bear upon said steel pin, and means acting upon the other end thereof to actuate the lever, substantially as specified. 80

In witness whereof I have hereunto signed my name in the presence of two subscribing witnesses. 85

RICHARD T. WINGO.

Witnesses:

PAUL HEILMANN,
AMAND RITTER.